

HS-420I/M Intrinsically Safe Accelerometer

4-20mA velocity output via Flame Retardant Cable

Key Features

- Intrinsically Safe with European, USA, Australian, South African, and Indian approvals
- Approved SIL 2 and SIL 3
- For use with PLC/DCS systems
- Low smoke, halogen free cable

Industries

Building services, Pulp and Paper, Mining, Metals, Utilities, Automotive, Water, Pharmaceutical

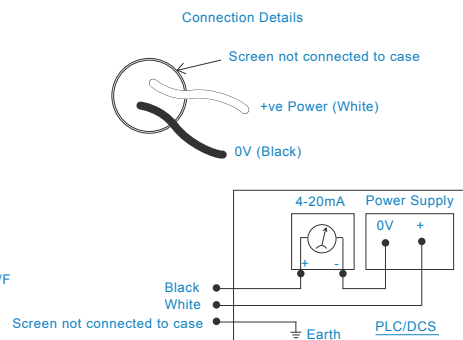
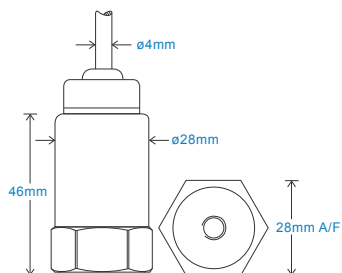

Technical Performance

Mounted Base Resonance	5kHz min
Velocity Ranges	see: 'How To Order' table $\pm 10\%$ Nominal 80Hz at 22°C
Frequency Response	10Hz (600cpm) to 1kHz (60kcpm) $\pm 5\%$ - ISO10816
Isolation	Base isolated
Range	50g peak
Transverse Sensitivity	Less than 5%

Mechanical

Case Material	Stainless Steel
Sensing Element/Construction	PZT/Compression
Mounting Torque	8Nm
Weight	150gms (nominal)
Maximum Cable Length	1000 metres
Standard Cable Length	5 metres
Screened Cable	Flame Retardant - length to be specified with order
Mounting Threads	see: 'How To Order' table

Electrical

Current Output	4-20mA DC proportional to Velocity Range
Supply Voltage	15-30 Volts DC (for 4-20mA)
Settling Time	2 seconds
Output Impedance	Loop Resistance 600 Ohms max. at 24 Volts
Case Isolation	$>10^8$ Ohms at 500 Volts

Environmental

Operating Temperature Range	see: attached certification details
Sealing	IP65
Maximum Shock	5000g
EMC	EN61326-1:2013

Typical Frequency Response

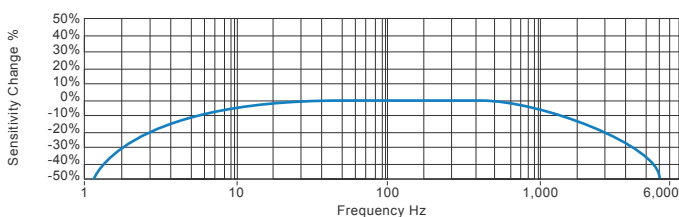

Applications

Fans, Motors, Pumps, Compressors, Centrifuges, Conveyors, Air Handlers, Gearboxes, Rolls, Dryers, Presses, Cooling, VAC, Spindles, Machine Tooling, Process Equipment

Vibration sensor should be firmly fixed to a flat surface (spot face surface may be needed to be produced and cable anchored to sensor body.)

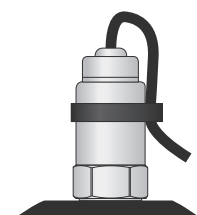

Certifications



This product is certified in accordance with
UL 913, 8th Ed. Rev. December 6, 2013
CAN/CSA C22.2 No. 157-92 (R2012) +Upd1 +Upd2



T: 150 210 98804
www.hansfordsensors.com.cn
 汉施弗德传感器（上海）有限公司



HS-420I/M Intrinsically Safe Accelerometer

4-20mA velocity output via Flame Retardant Cable

Intrinsically Safe Requirements

Maximum Cable Length	nominal 100 metres see attached system drawings	US/Canada Approvals	Certificate No. SGSNA/18/SUW/0000231 Class I, II, III, Division 1, 2, Groups A - G, T4, -40°C to +110°C, Class I, Zone 0, AEx, ia, IIC, T4, Ga, -40°C to +110°C
Certificate details: Group I + II	IECEX BAS08.0034X Baseefa08ATEX0086X ⓈII 1GD Ex ia IIC T6 Ga Ex ia IIIC T80°C IP65 Da ⓈI M1 Ex ia I Ma (-40°C ≤ Ta ≤ +60°C)	Barrier	1 x Pepperl + Fuchs Galvanic Isolator KFD2-STC4-Ex1, which has superseded KFD2-CR-Ex1.30300 (BAS00ATEX7164) see attached system drawings
Certificate details: Group II	ⓈII 1GD Ex ia IIC T4 Ga Ex ia IIIC T130°C IP65 Da (-40°C ≤ Ta ≤ +110°C)		1 x MTL Zener Barrier MTL7787+ (BAS01ATEX7217) or Pepperl + Fuchs Zener Barrier Z787 (BAS01ATEX7005) or any other barrier that conforms to system drawings attached
Accelerometer System Certificate	Baseefa08Y0087 Ex ia IIC T6 (-40°C ≤ Ta ≤ +60°C) *On request - consult Sales Office	System Connections for Zener Barrier	see attached system drawings
		System Connections for Galvanic Isolator	see attached system drawings
Terminal Parameters	Ui = 28V, li = 115mA, Pi = 0.65W Group II Ui = 16.5V Pi = 0.65W or Ui = 28V li = 115mA Pi = 0.65W Group I	Terminal Parameters	Ui = Vmax = 28V li = Imax = 115mA Pi = 0.65W
500V Isolation	Units Will Pass A 500V Isolation Test	Notes:	Special conditions of safe use for Group II dust. The free end of the cable on the integral cable version of the apparatus must be terminated in an appropriately certified dust-proof enclosure. The unit has no serviceable parts.
Certified Temperature Range	Ex ia IIC T6 Ga (-40°C ≤ Ta ≤ +60°C) (Gas) Ex ia IIC T4 Ga (-40°C ≤ Ta ≤ +110°C) (Gas) Ex ia IIIC T80°C IP65 Da (-40°C ≤ Ta ≤ +60°C) (Dust) Ex ia IIIC T130°C IP65 Da (-40°C ≤ Ta ≤ +110°C) (Dust) Ex ia I Ma (-40°C ≤ Ta ≤ +60°C) (Mining)		
Australia Approval Group 1	IECEX ITA 10.0003X Ex ia I Ma (-40°C ≤ Ta ≤ +60°C)		
South African Approval	Certificate No. MASC MS/16-0229X Group I and II (As Baseefa/ATEX)		

How To Order

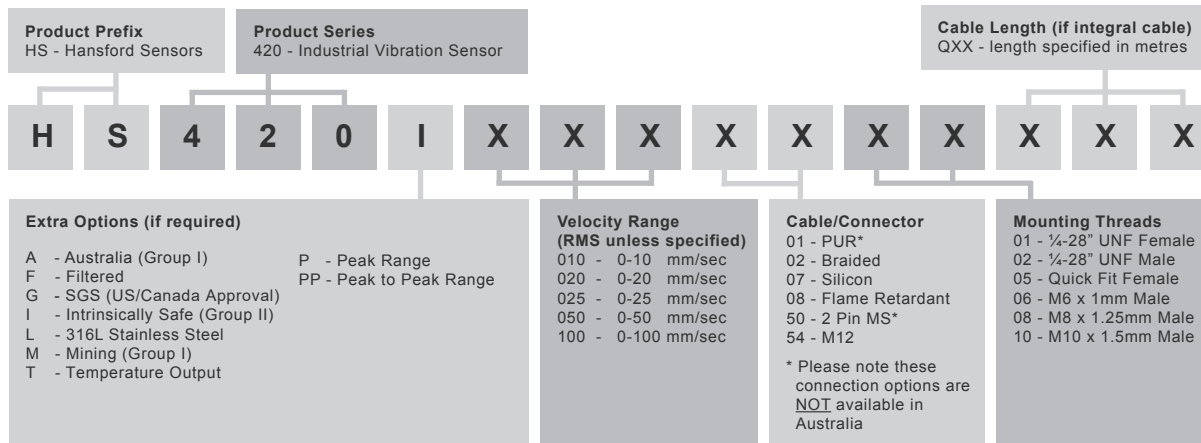

T: 150 210 98804
www.hansfordsensors.com.cn
汉施弗德传感器（上海）有限公司



Non-hazardous area apparatus which is unspecified except that it must not be supplied from nor contain under normal or abnormal conditions, a source of potential with respect to earth in excess of 250 volts DC. under normal conditions the potential at the connections to the galvanic isolator must not exceed 40 volts DC.

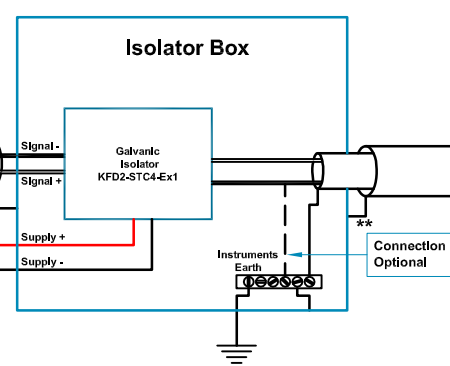

See Table 1

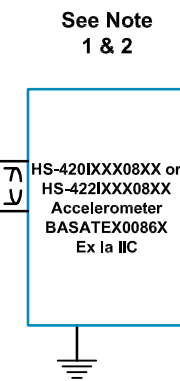
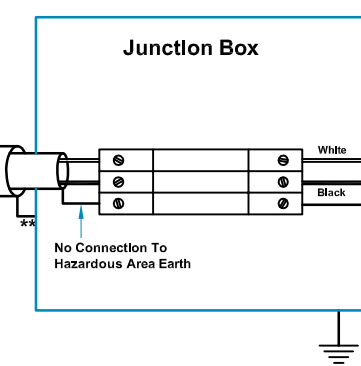

Table 1: Cable Parameters For Additional Cable Lengths

Accelerometer With Integral Cable Length ≤ 10m		
Group	Capacitance μF	L/R Ratio μH/Ω
IIC	0.097	72
IIB	0.768	277
IIA	2.598	585
Accelerometer With Integral Cable Length ≤ 50m		
Group	Capacitance μF	L/R Ratio μH/Ω
IIC	0.091	72
IIB	0.762	277
IIA	2.592	585
Accelerometer With Integral Cable Length ≤ 100m		
Group	Capacitance μF	L/R Ratio μH/Ω
IIC	0.083	72
IIB	0.754	277
IIA	2.584	585

Hansford Sensors Ltd
 HS-420I & HS-422I
 Accelerometer System
 Ex ia IIC T6 (-40°C ≤ Ta ≤ +60°C)

- Notes:**
- The capacitance and inductance, or inductance - to - resistance ratio (L/R) of hazardous area cable, must not exceed the values shown in Table 1.
 - The cable from the accelerometer to the junction box must not be installed in a high velocity dust laden atmosphere.
 - The installer is to perform a risk assessment in accordance with clause 10 of EN 60079-25 and install lightning protection arrestors as deemed necessary.

Rev No	DRF No	Date Drg	Drg By	Appd By	Material: N/A
A	Release	17/06/10	MJS	CMH	
					Tolerances Unless Stated
					0 or 0.0 ±0.5
					0.00 ±0.15
					Angle ±5°
					1.6/∇ Finish All Over
					Threads g6 H6

Hansford Sensors Ltd
 Saunderton Business Park
 Haw Lane
 Saunderton
 Bucks HP14 4JE

Do Not Scale

All Dimensions In mm Unless Otherwise Stated

If In Doubt - Ask!

Description: System Connections For HS-420I & HS-422I Group II Accelerometers With Non Armoured FR Polyurethane Cable F.U.W. Galvanic Isolation

Drawing No: M06-033-A

Scale: NTS

Sheet: 1 of 1

Form Number: QF024 Issue 1

Non-hazardous area apparatus which is unspecified except that it must not be supplied from nor contain under normal or abnormal conditions, a source of potential with respect to earth in excess of 250 volts rms or 250 volts dc. under normal conditions the potential at the connections to the zener barrier must not exceed 40 volts dc.

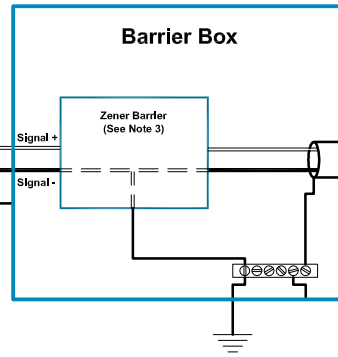

See Table 1

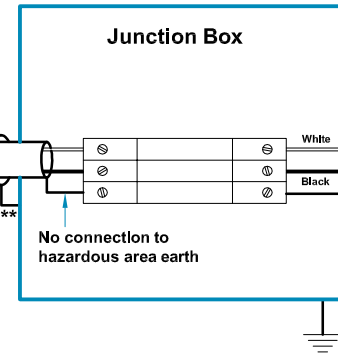

**Outer shield only connected to chassis via Ex approved cable gland

See Note 1 & 2



Table 1: Cable Parameters For Additional Cable Lengths

Accelerometer With Integral Cable Length ≤ 10m		
Group	Capacitance µF	L/R Ratio µH/Ω
IIC	0.081	56
IIB	0.247	168
IIA	0.662	448
Accelerometer With Integral Cable Length ≤ 50m		
Group	Capacitance µF	L/R Ratio µH/Ω
IIC	0.075	56
IIB	0.241	168
IIA	0.656	448
Accelerometer With Integral Cable Length ≤ 100m		
Group	Capacitance µF	L/R Ratio µH/Ω
IIC	0.067	56
IIB	0.233	168
IIA	0.648	448



Baseefa Certification Schedule Drawing

baseefa 08 Y 0087

Hansford Sensors Ltd

HS-4201 & HS-4221 Accelerometer System Baseefa08Y0087 Ex ia IIC T6 (-40°C ≤ Ta ≤ +60°C)

Notes:

- The capacitance and Inductance, or Inductance - to - resistance ratio (L/R) of hazardous area cable, must not exceed the values shown in Table 1.
- The cable from the accelerometer to the junction box must not be installed in a high velocity dust laden atmosphere.
- Any shunt zener diode safety barrier certified by an ec approved body to [EEEx ia] IIC having the following output parameters: U_o = 28V dc, I_o = 93mA dc, P_o = 0.65W. e.g. MTL7787 to BAS01ATEX7217 or Pepperl + Fuchs Z787 to BAS01ATEX7005.
- The installer is to perform a risk assesment in accordance with clause 10 of EN 60079-25 and install lightning protection arrestors as deemed necessary.

Rev No	DRF No	Date Drg	Drg By	Appd By	Material: N/A
A	Release	10/03/08	MJS	CMH	

Tolerances Unless Stated
 0 or 0.0 ±0.5
 0.00 ±0.15
 Angle ±5°
 Finish All Over
 Threads g6 H6

Hansford Sensors Ltd
 Saunderton Business Park
 Haw Lane
 Saunderton
 Bucks HP14 4JE

Do Not Scale
 All Dimensions In mm Unless Otherwise Stated

If In Doubt - Ask!

Description: System Connections For HS-4201 & HS-4221 Group II Accelerometers With Non Armoured FR Polyurethane Cable F.U.W. Zener Barrier
 Drawing No: M06-013-A
 Scale: NTS
 Sheet: 2 of 2
 Form Number: QF024 Issue 1